

20~1000kg

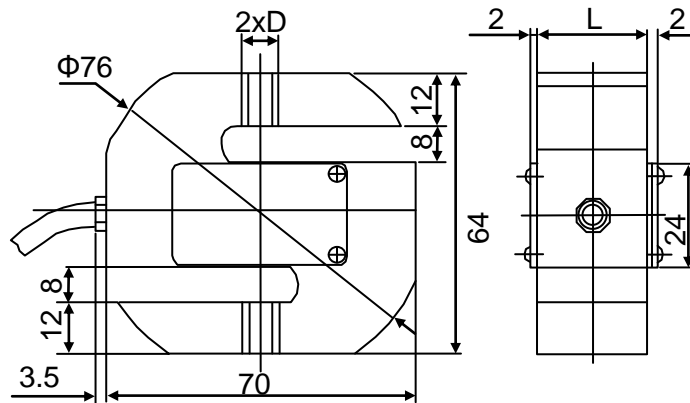

Crane scale, blending scale, packing scale, electromechanical scale, special testing device

1.5~7.5t

(kg) Rated Load	D	L
20~150	M8	12
200~500	M12	20
700~1000	M12	25

(t) Rated Load	D(mm)	L(mm)	H
1.5~5	M20	32	88
7.5	M24	40	88

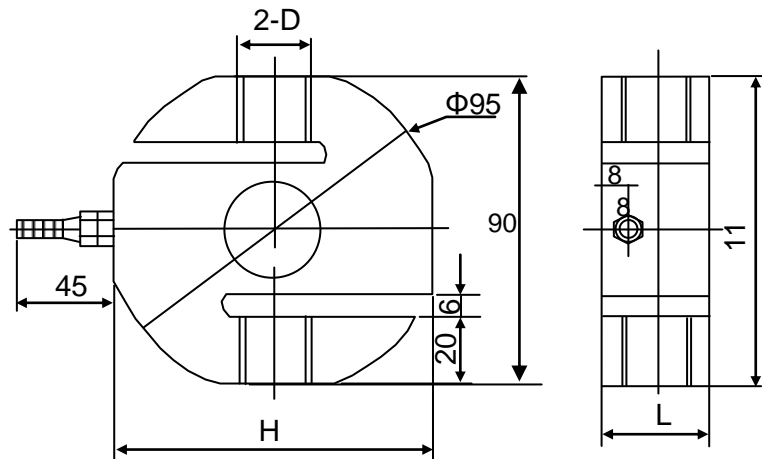

Technical Parameter

4Wires : Exc+(Red); Exc-(Black); Sig+(Green); Sig-(White)

Rated load	20kg、30kg、50kg、75kg、100kg、150kg、200kg、250kg、300kg、500kg、700kg、750kg、1t、1.5t、2t、3t、5t、7.5t		
Accuracy class	0.03	Nominal Temp Range	-10°C ~ +40°C
Sensitivity	2.0±0.003mV/V	Service Temp Range	-30°C ~ +70°C
Non-linearity	±0.03%F.S	Safe load limit	150%F.S
Hysteresis error	±0.03%F.S	Breaking load	200%F.S
Creep error(30min)	±0.03%F.S	Nominal of range excitation	10~12 VDC
TC ZERO	±0.02F.S/10°C	Protection Class	IP66(20kg~1t), IP68(1.5t~7.5t)
TC SPAN	±0.02F.S/10°C	Material	Alloy Steel
Input resistance	400±20Ω (1.5t~7.5t)		Stainless Steel
Output resistance	352±5Ω	Cable Length	2.6m(20kg~1t)
Insulation resistance	≥5000MΩ		3m(1.5t~7.5t)

Diagram B

20kg~1t

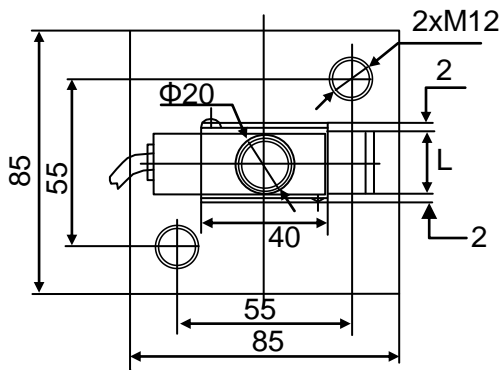
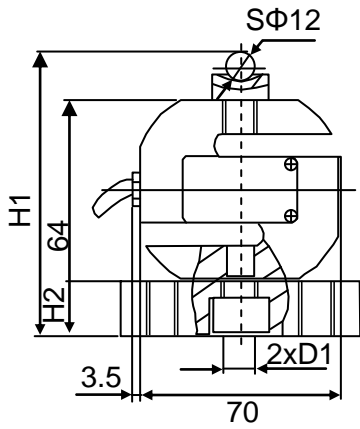

(kg) Rated Load	H1	H2	D1	L
20~150	97	15	M8	12
200~500	103	19	M12	20
700~1000	103	19	M12	25

2t~7.5t

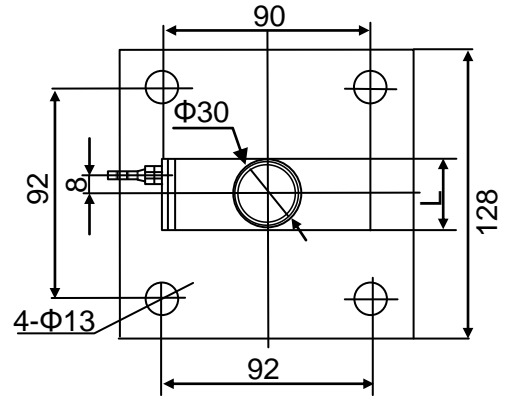
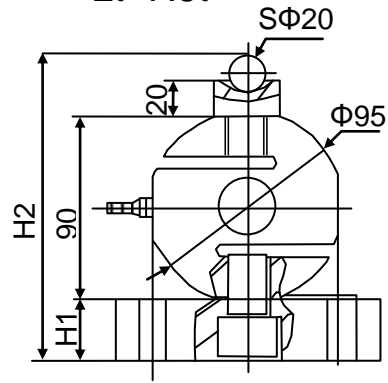

(t) Rated Load	H1	H2	D1
2~5	29	151	32
7.5	34	156	40

Diagram D

20kg~5t

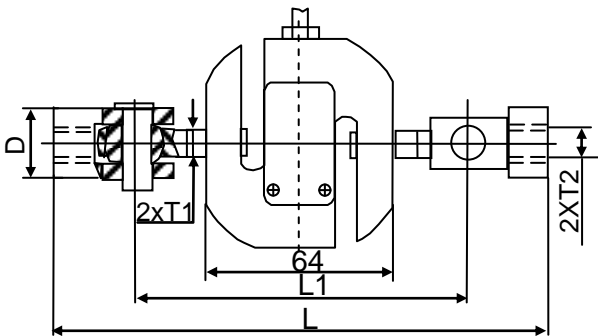

Rated Load	L max	L1max	T1	T2	D
20~150	184	124	M8	M8	Φ24
200~500	228	148	M12	M12	Φ34
700~1000	228	148	M12	M12	Φ34
2t~5t	326	206	M20	M24	Φ56

Diagram E

20kg~300kg

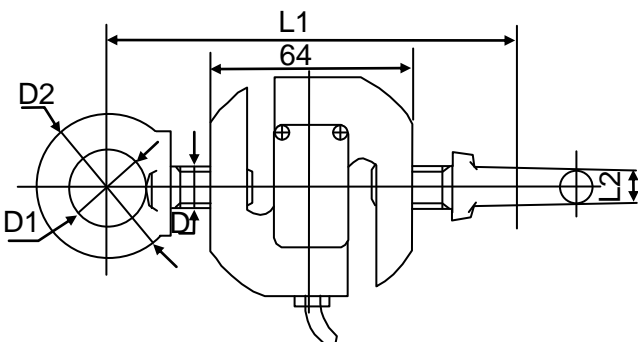

(kg) Rated Load	D	D1	D2	L1max	L2
20~150	M8	Φ20	Φ36	108	9
200~300	M12	Φ28	Φ52	136	13